



**BE SERIES MANUAL TEST BENCH
OPERATORS MANUAL**



SAFETY PRECAUTIONS



READ INSTRUCTIONS AND IDENTIFY ALL COMPONENT PARTS BEFORE OPERATING BENCH

TEST BENCH PRODUCES EXTREMELY HIGH PRESSURE. USE CAUTION WHEN OPERATING

KEEP HANDS AWAY FROM PINCH POINTS

CONSULT HOSE AND FITTING MANUFACTURER'S SPECIFICATIONS FOR CORRECT TESTING PROCEDURE

ALWAYS WEAR EYE PROTECTION

**For Parts and Service, Contact:
Custom Machining Services, Inc.
Valparaiso, In 46383
(219) 462-6128**

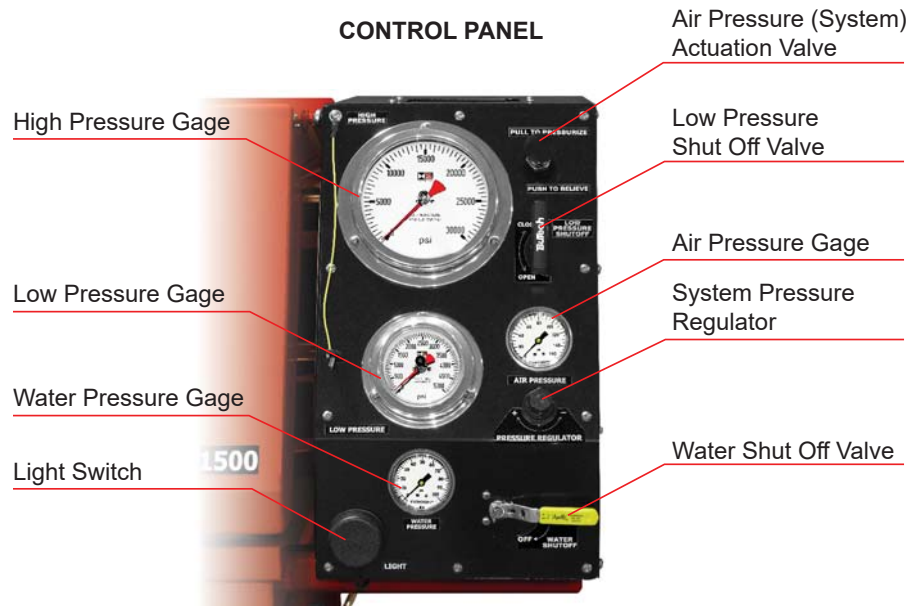

- Connect a water supply hose to the water inlet connection which is located at the rear of the control cabinet.
- Connect a water drain hose to the water drain connection located at the rear of the test bench. Run the drain line to an appropriate drainage area.
- Connect an air supply (80 psi Max) to the air inlet/ filter.

Note: For optimum performance an air supply of 28 SCFM is recommended

- Plug the electrical cord into a standard 110VAC outlet. (Electrical power is required only to operate the work light and is not required to operate the test bench)

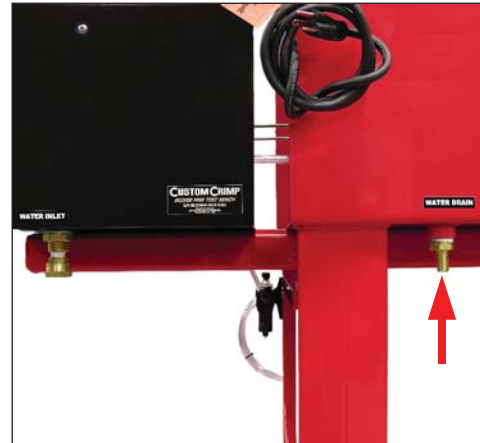

WATER DRAIN VALVE

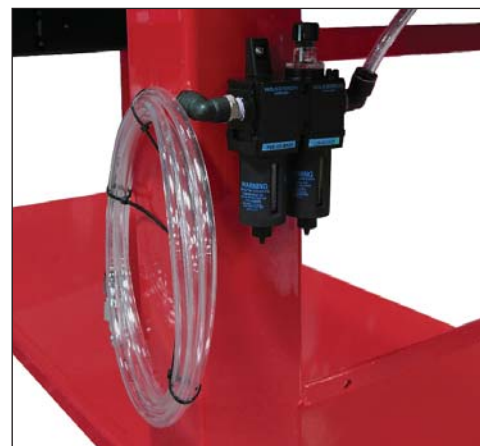

AIR INLET (FILTER/LUBRICATOR)

- Prior to operating bench, make sure that the pressure regulator knob is adjusted all the way out (counter-clockwise).
- Raise the tank lid by pushing button and lifting up on handle.
- Attach hose to be tested to the manifold inside the tank. The standard manifold has 4 ports out the side and 2 ports on top. Any port can be used for testing hoses.
- Note: The manifold port threads are a special high-pressure coned configuration that only accepts the proper mating fittings. (Adapters are available to connect various thread sizes to the manifold.)
- Secure the supplied plugs in unused manifold ports.
- Place supplied rubber safety mat over hose. If bursting, cover hose assembly with a rubber mat to contain assembly.
- Lower tank lid and make sure latch engages to ensure it is fully closed.



- Adjust pressure regulator knob all the way down (counter-clockwise).
- Set the gauge maximum indicating pointer to zero.
- Close the low pressure shut off valve to protect the low pressure gauge (if equipped).

Note: Failure to close the low pressure shut off valve can result in damage to the gauge.

- Turn on water shutoff valve.
- Pull the Air Pressure Actuation Valve palm button to begin test and pressurize system.
- Begin increasing pressure by turning pressure regulator knob clockwise. Take care to increase regulator slowly as system pressure may spike between pump strokes.
- Low pressure operation: (If equipped with both a low and high pressure gauge.

Make sure system pressure is well below 5000 psi prior to opening low pressure valve.

- Open the low pressure shut off valve.
- Increase regulator pressure slightly to get a low pressure reading.

Prior to reaching full pressure on the low pressure gauge, close the low pressure shut off valve to protect gauge.

- A maximum pressure of no more than 4500 psi is recommended for this gauge.
- Continue test using high pressure gauge.



- Increase pressure regulator until system reaches desired pressure on high pressure gauge.
- Turn pressure regulator knob counter-clockwise to decrease air pressure.
- Push Air Pressure Actuation Valve palm button to relieve system pressure and end test.
- Record maximum pressure indicated by pointer on gauge.
- Open tank lid and remove tested hose.

Note: Opening the cover at any time will relieve system pressure. This is a safety feature and should not be circumvented.



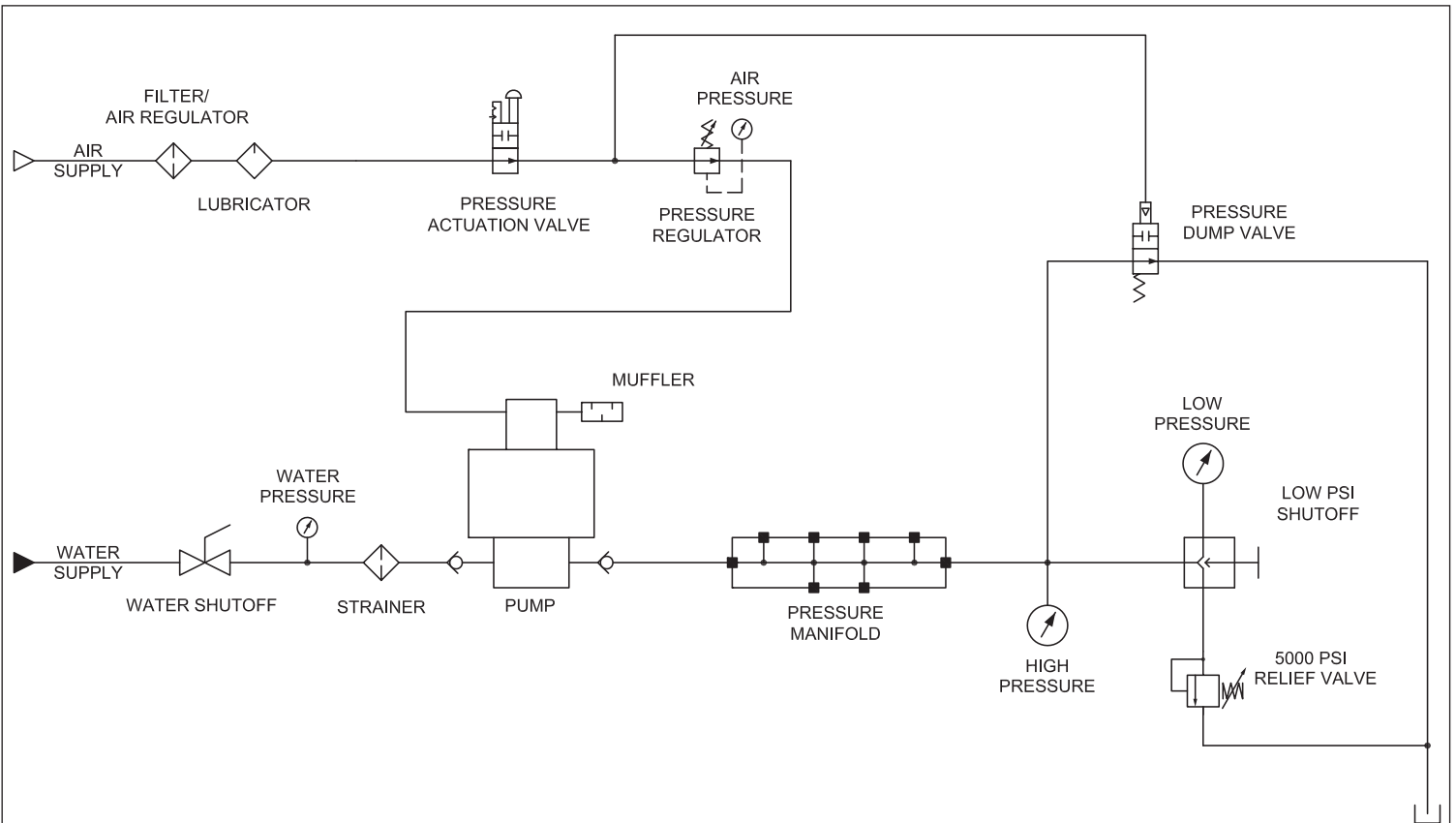

ADJUSTING THE PRESSURE RELEASE VALVE

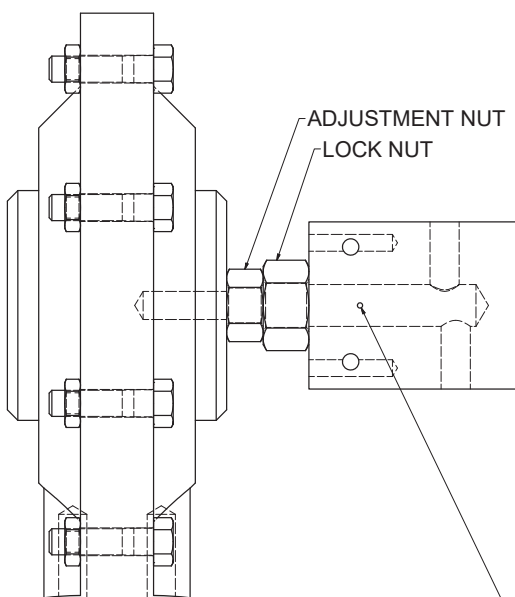

- Follow the instructions on page 9-10.

WEEP HOLE.
IF PACKING IS NOT
TIGHT ENOUGH, WATER
WILL COME OUT THIS HOLE.

1). Disconnect the Air Line.

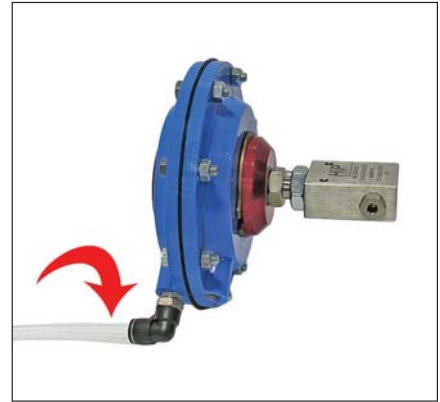

2). Use a 1" wrench to grab the Adjustment Nut and with a 1-1/8" wrench to loosen the Lock Nut, until spins freely.

(Adjustment Nut will be closest to Blue Diaphragm).



3). Rotate the Blue Diaphragm counter-clockwise to remove it from the Block.



4). Clean the Blue Diaphragm Needle and apply grease. Remove the Packing from the block and clean them. Place the Packing on the Blue Diaphragm Needle.

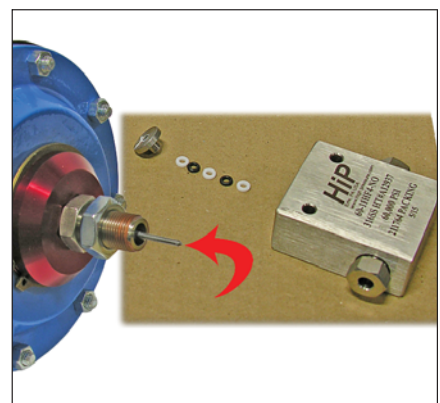

- 5). The Packing must follow the order as shown.
Apply grease all over the packing.



- 6). Place the Blue Diaphragm Needle (Packing installed) into the Block and rotate the Blue Diaphragm clockwise until you can feel the packing (Seals) make contact with the valve cone.

Note: Do not tighten past this point, damage to stem and packing can occur. Tightening past this point will begin to compress the packing and will also make the stem stick again.



- 7). Use a 1 inch wrench to grab the Adjustment Nut and with a 1-1/8" wrench to tighten the Lock Nut. (Just snug tight).



- 8). Connect the Air Line back into the fitting and test out the unit to check the adjustment.

- If water comes out of weeping hole than go back to step 6 and snug stem slightly more.

Note: The objective is to tighten the Adjustment Nut so that the packing seals around the needle and still allows the Blue Diaphragm to move the needle back and forth to build pressure and drain.

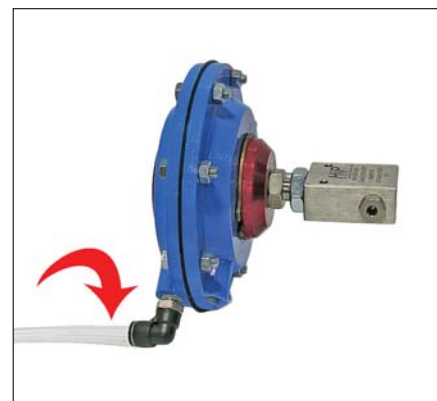



1/4" NPT P/N:103687-04



3/8" NPT P/N:103687-06



1/2" NPT P/N:103687-08



3/4" NPT P/N:103687-12



1/2" JIC P/N:104428-08



3/8" JIC P/N:104428-06



2WAY NEEDLE VALVE P/N:104352



5000 PSI RELIEF VALVE P/N:104642



RELIEF VALVE P/N:104241



REPAIR KIT P/N:104241-KIT



AIR REGULATOR P/N:104115



MANIFOLD BLOCK P/N:102100



BE 1500 PUMP P/N:103860



BE 2500 PUMP P/N:103861



BE 3500 PUMP P/N:103862



5000 PSI GAUGE P/N:104130



30,000 PSI GAUGE P/N:104131



40,000 PSI GAUGE P/N:104132



60,000 PSI GAUGE P/N:104133



CustomCrimp “No-Nonsense” Warranty Statement

All CustomCrimp Products are warranted to be free of defects in workmanship and materials for one year from the date of installation. This warranty ends when the product becomes unusable for reasons other than defects in workmanship or material.

Any CustomCrimp Product proven to be defective in workmanship or material will be repaired or replaced at no charge. To obtain benefits of this warranty, first, contact Warranty Repair Department at Custom Machining Services at **(219) 462-6128** and then deliver via prepaid transportation the complete hydraulic product to:

**ATTN: WARRANTY REPAIR DEPT.
Custom Machining Services, Inc.
326 North Co. Rd 400 East
Valparaiso IN 46383**

If any product or part manufactured by CustomCrimp is found to be defective by CustomCrimp, at its option, CustomCrimp will either repair or replace the defective part or product and return via ground transportation, freight prepaid. **Custom Crimp will not cover any incoming or outgoing freight charges for machines sold outside The United States.**

This warranty does not cover any product or part which is worn out, abused, altered, used for a purpose other than for which it was intended, or used in a manner which was inconsistent with any instructions regarding its use.

Electric motors are separately warranted by their manufacturer under the conditions stated in their separate warranty.

Custom Crimp®
Custom Machining Services, Inc.
326 N. County Rd. 400 East
Valparaiso, IN 46383
Ph: (219) 462-6128
Fax: (219) 464-2773
www.customcrimp.com



CustomCrimp®

See the complete line of CustomCrimp® Crimpers and Accessories at:
www.customcrimp.com

(219) 462-6128
